

4

3

2

1

ITEM NO.	DESCRIPTION	QTY.
1	TOP LEVEL SHEET METAL	1
2	BILL VALIDATOR	1
3	BEZEL	1
4	22" LCD	1
5	PC	1
6	TRACKBALL	1
7	AUDIO JACK	1
8	80MM TICKET/RECEIPT PRINTER	1
9	CARD READER	1
10	CHECK SCANNER	1
11	TECA, A/C UNIT	1
12	POWER STRIP	1
13	ATM SECURITY LOCK	1
14	WIRELESS CAMERA	1
15	SPEAKER	2
17	DOOR SHOCK	1
18	POWER STRIP	1
20	LOCK	4

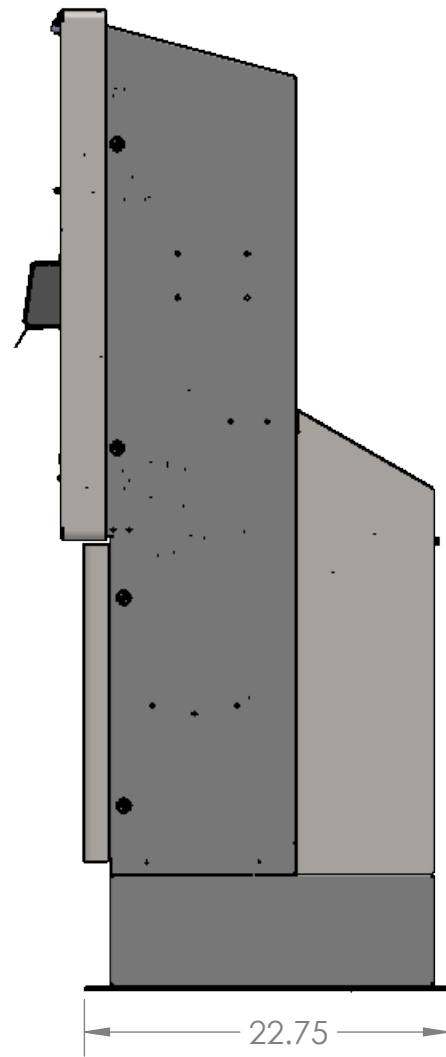
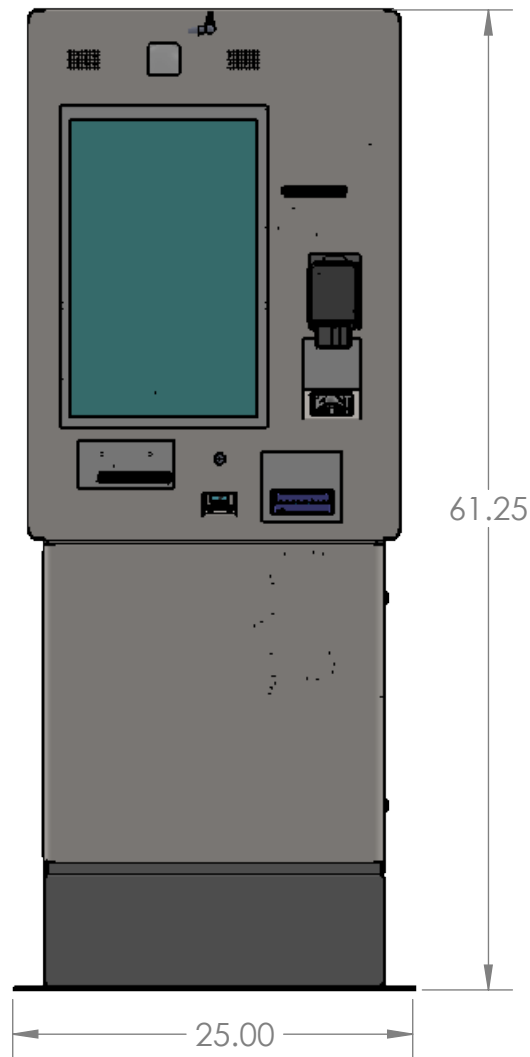
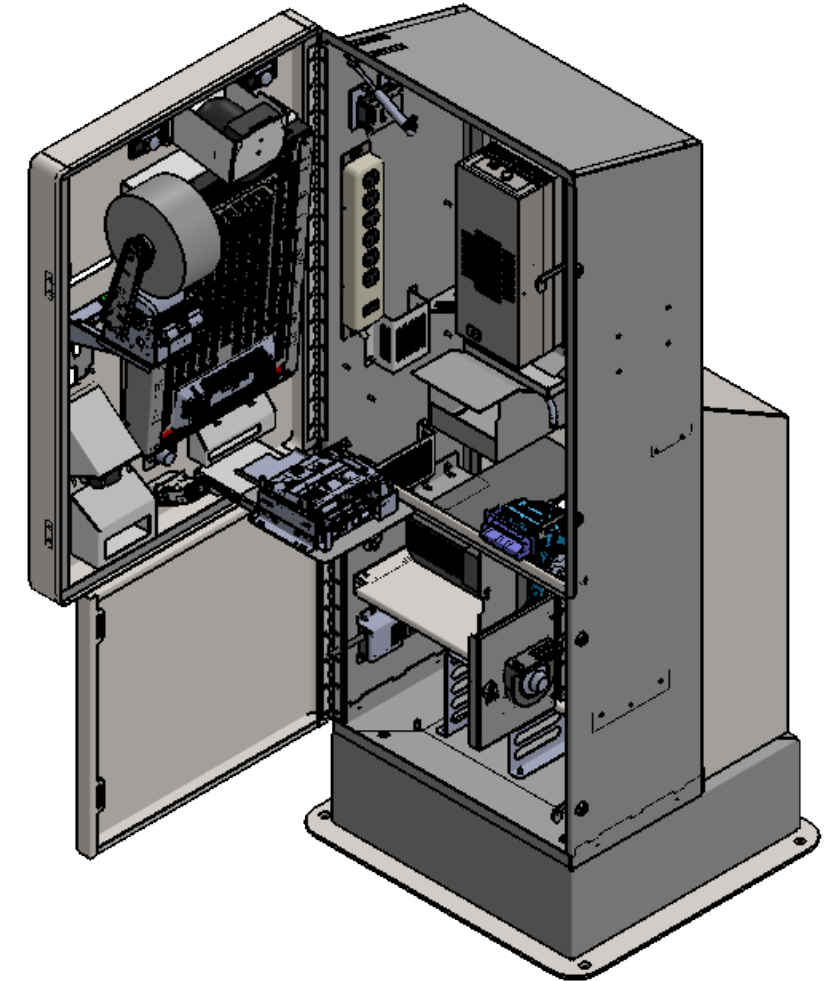
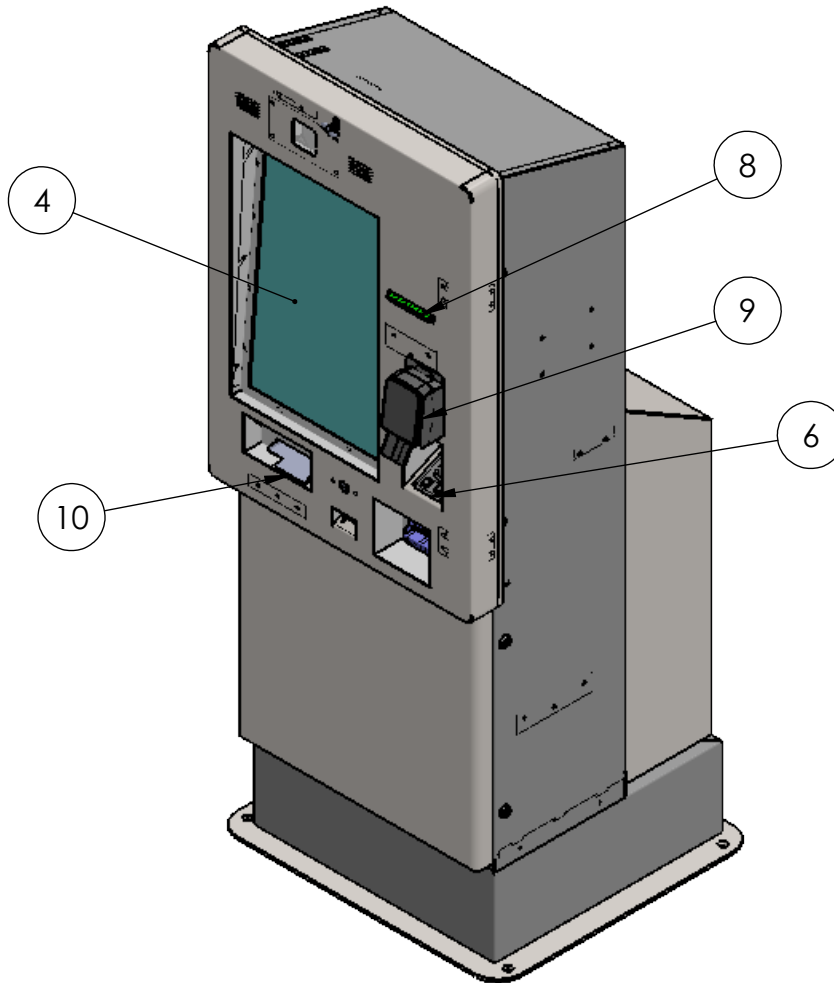

PROPRIETARY AND CONFIDENTIAL
 THE INFORMATION CONTAINED IN THIS DRAWING IS THE SOLE PROPERTY OF <INSERT COMPANY NAME HERE>. ANY REPRODUCTION IN PART OR AS A WHOLE WITHOUT THE WRITTEN PERMISSION OF <INSERT COMPANY NAME HERE> IS PROHIBITED.

		UNLESS OTHERWISE SPECIFIED:		NAME	DATE	SlabbKiosks	
		DIMENSIONS ARE IN INCHES TOLERANCES: FRACTIONAL ± ANGULAR: MACH ± BEND ± TWO PLACE DECIMAL ± .030 THREE PLACE DECIMAL ± .015		DRAWN	C.HOLSKE		
		INTERPRET GEOMETRIC TOLERANCING PER:		CHECKED			TITLE: DRIVE THRU/OUTDOOR, TOP LEVEL ASSY
		MATERIAL		ENG APPR.			
		FINISH		MFG APPR.			SIZE DWG. NO. REV
NEXT ASSY	USED ON	SEE PARTS		Q.A.			B F2-XO A
APPLICATION		DO NOT SCALE DRAWING		COMMENTS:			SCALE: 1:16 WEIGHT: SHEET 1 OF 1

4

3

2

1

B

B

A

A