

ITEM NO.	DESCRIPTION	OPEN DOOR/QTY.
1	TOP LEVEL SHEET METAL	1
2	BILL ACCEPTOR	1
3	BEZEL	1
4	Cash Dispenser	1
5	22" LCD	1
6	PC	1
7	BATTERY BACKUP	1
8	TRACKBALL	1
9	LOCK	4
10	AUDIO JACK	1
11	CARD READER	1
12	Check Scanner	1
13	PRINTER	1
14	POWER STRIP (4 OUTLET)	1

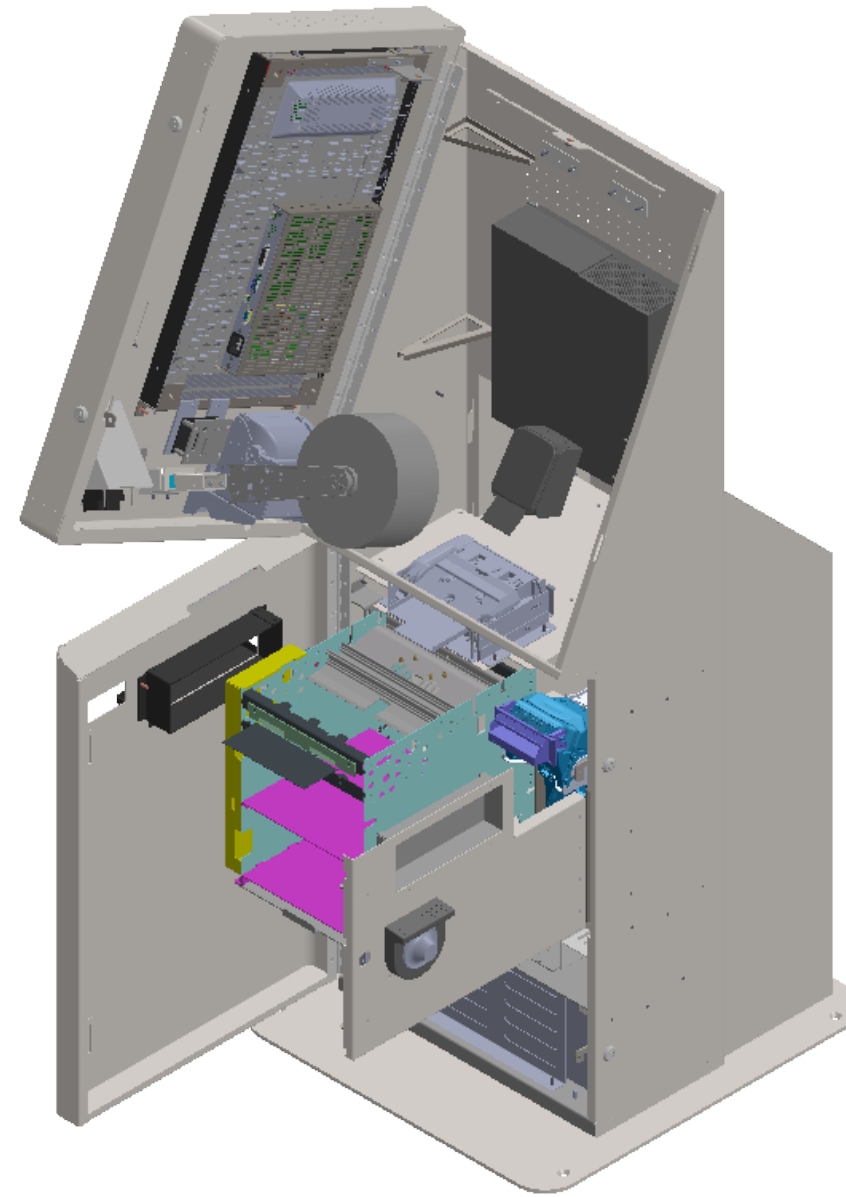
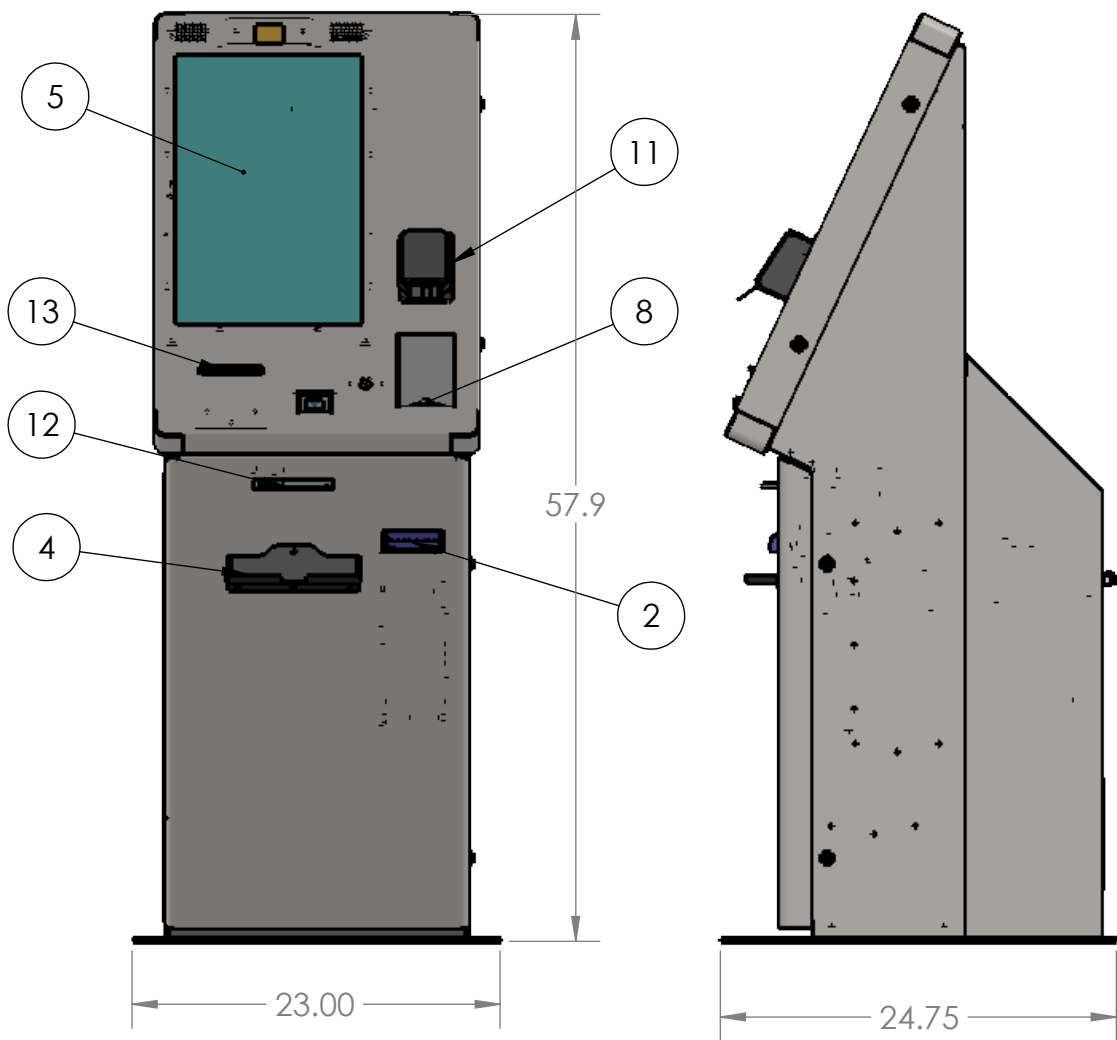

**PROPRIETARY AND CONFIDENTIAL**  
 THE INFORMATION CONTAINED IN THIS DRAWING IS THE SOLE PROPERTY OF <INSERT COMPANY NAME HERE>. ANY REPRODUCTION IN PART OR AS A WHOLE WITHOUT THE WRITTEN PERMISSION OF <INSERT COMPANY NAME HERE> IS PROHIBITED.

		UNLESS OTHERWISE SPECIFIED:	NAME	DATE	SlabbKiosks	
		DIMENSIONS ARE IN INCHES TOLERANCES: FRACTIONAL ± ANGULAR: MACH ± BEND ± TWO PLACE DECIMAL ± .030 THREE PLACE DECIMAL ± .015	DRAWN	C.HOLSKE		
		INTERPRET GEOMETRIC TOLERANCING PER:	CHECKED			TITLE: INDOOR FLOOR - TOP LEVEL ASSY
		MATERIAL	ENG APPR.			SIZE DWG. NO. REV B F2-XO A
NEXT ASSY	USED ON	FINISH SEE PARTS	MFG APPR.			SCALE: 1:24 WEIGHT: SHEET 1 OF 1
APPLICATION		DO NOT SCALE DRAWING	Q.A.			
			COMMENTS:			